



Van Step Installation Ford, all full size Kit #907520000

© 2/04 Kwikkee Products Co., Inc.
Kwikkee #1420760 Rev. 2 2/04

Van Step Installation Instructions

Fits all full size Fords, Kit #907520000

Mounting Bracket Installation

1. Locate and drill four 5/16" diameter holes in the step well for the upper mounting bolts. See *Figures 1 and 2*. **NOTE: Carefully measure the 1" and 1 1/2" dimensions down from the steel floor surface. Do not measure from the floor covering or any kind of trim.**
2. Bolt the top of both mounting brackets in place using the 5/16-18 hex head bolts and the wing nuts that are included in alignment jig. Refer to *Figure 2*. **NOTE: Do not use the 5/16-18 nylock type nuts until the final mounting procedures.**
3. Bolt the alignment jig to the studs in the mounting brackets using the wing nuts supplied with the alignment jig.

Tighten all wing nuts. **NOTE: the alignment jig is not necessary for the installation of the step, however, Kwikkee cannot guarantee proper alignment of the mounting brackets without it.**

4. On 1-ton vans, mark the positions of the holes in the back end of both mounting brackets with the tail piece in the down position as shown in *Figure 2*.

On 1/2- and 3/4-ton vans rotate the tail piece to the up position as shown in *Figure 2* before marking the locations. **NOTE: These positions must be very accurate.**

5. **NOTE: Leave the alignment jig attached to the mounting brackets and remove the mounting brackets and the alignment jig as a unit.**

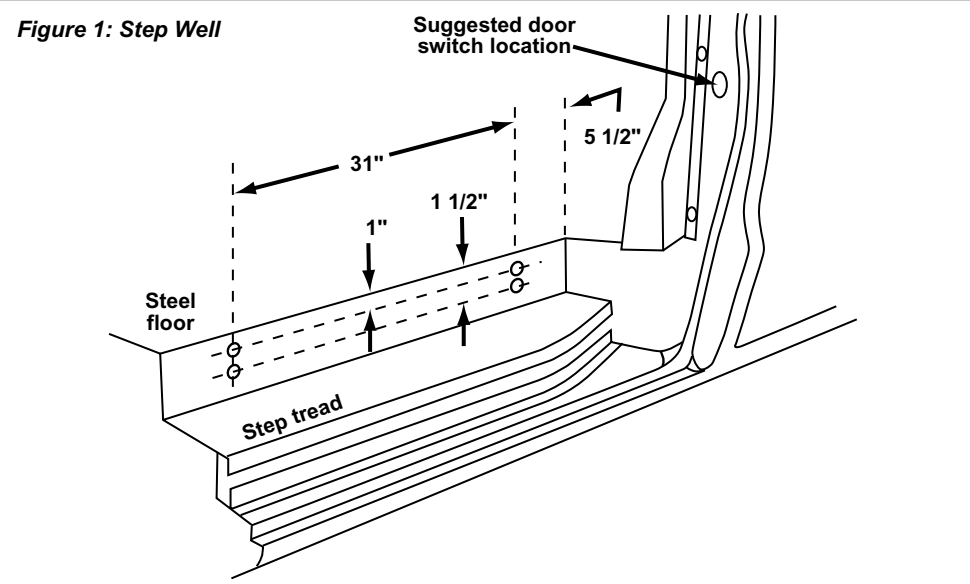

Read all instructions before beginning. Disconnect the vehicle battery before beginning any installation or wiring procedure. Follow instructions in sequence. Safety glasses should be worn while performing installation.

MOUNTING BRACKET PARTS

Qty	Description
2	Mounting brackets
4	5/16-18 x 1" long hex head bolts
2	5/16-18 x 1 1/4" long hex head bolts
9	5/16" flat washers
10	5/16" split lock washers
10	5/16-18 nylock type nuts
4	1/4-20 x 1" long hex head bolts
4	1/4" split lock washers
4	1/4-20 hex nuts
1	5/16" x 1" long sheet metal screw
1	Instructions

OTHER TOOLS NEEDED

- drill motor
- 1/4" dia. drill
- 5/16" dia. drill
- 9/32" dia. drill
- socket wrench
- 7/16" socket
- 1/2" socket (deep)
- Alignment jig (30 series step) Part 7550, available from Kwikkee (see Note in Step 3)
- 7/16" combination or open end wrench
- 1/2" combination or open end wrench
- pencil or marker
- flashlight or drop light
- safety glasses

Van Step Installation Instruction: Ford

6. Drill 9/32" diameter holes in the frame at the marks transferred from the back end of the mounting brackets at tail piece. **NOTE: These positions must be accurate.**
7. Bolt the top of the mounting brackets in place using the 5/16-18 x 1" hex head bolts. **NOTE: Leave the alignment jig attached.** Use the 5/16-18 hex head bolts, 5/16" flat washers, 5/16" split lock washers, and the 5/16-18 nylock type nuts. Do not tighten. Refer to *Figure 2*.

WARNING: Do not reuse the nylock type nuts. Replace with new nylock type nuts if used.

NOTE: Do not use the wing nuts for permanent mounting of the brackets.

8. Attach the rear of the mounting bracket tail piece in place using two 1/4-20x1" long hex head bolts, two 1/4" split lock washers and two 1/4-20 nylock type hex nuts on each bracket tail piece.
9. Tighten all mounting nuts and bolts. Remove the alignment jig from the mounting brackets only after all the bolts have been tightened.

Step Installation

1. It is recommended that all wiring to the step be in place before mounting the step to the mounting brackets.
2. The step should be in its extended position for ease of mounting. Use 10 gauge wire for jumpers to extend the step. **CAUTION: Keep hands clear of the step mechanism.**

Place the step upside-down on its mounting surface.

Ground the negative (-) post of a 12-volt dc battery to the ring terminal of the 31" long 10 gauge green ground wire from the control unit.

Plug the four way plug* into the plug leading from the step control unit. *Plug included in wiring kit or may be ordered separately - Kwikkee Part No. 909306000.

Connect the 10 gauge jumper wire between the positive (+) post of the battery and the red and white wire leads on plugs with four wire leads or just the red wire on plugs with two wire leads.

TOUCH the motor's yellow wire to the negative (-) post of the battery to extend the step.

Disconnect the jump wire from the battery. The step will stay in the extended position and is ready for mounting.

3. Mount the step to the studs in the mounting brackets attached to the vehicle. Use the 5/16" flat washers, 5/16" split lock washers, and 5/16-18 nylock type nuts to attach the step to the mounting brackets. Tighten all nuts. Refer to *Figure 2*. **WARNING: Do not re-use the nylock nuts. Replace with new nylock type nuts if used.**
4. Drill a 1/4" dia. hole in the vehicle's frame to attach the 10 gauge green ground wire. Scrape the paint clear around the hole to achieve a good ground connection.
5. Attach the 10 gauge green ground wire from the step control unit to the vehicle's chassis. Use the 5/16" x 1" long sheet metal screw and a 5/16" flat washer. **NOTE: A good ground connection is a must to ensure proper step operation.**
6. Tie the ground wire up out of the way so it will not interfere with the step or the vehicle operation.

Figure 2: Mounting Bracket

